

Heavy Duty 8' Accessible Picnic Table

Model: 650547

knill
Fabrication Ltd.
519-442-2424

Featuring 2 x 10 Pressure Treated Wood Planks

- Specifications and Assembly Instructions -

Rev.: 15Oct21

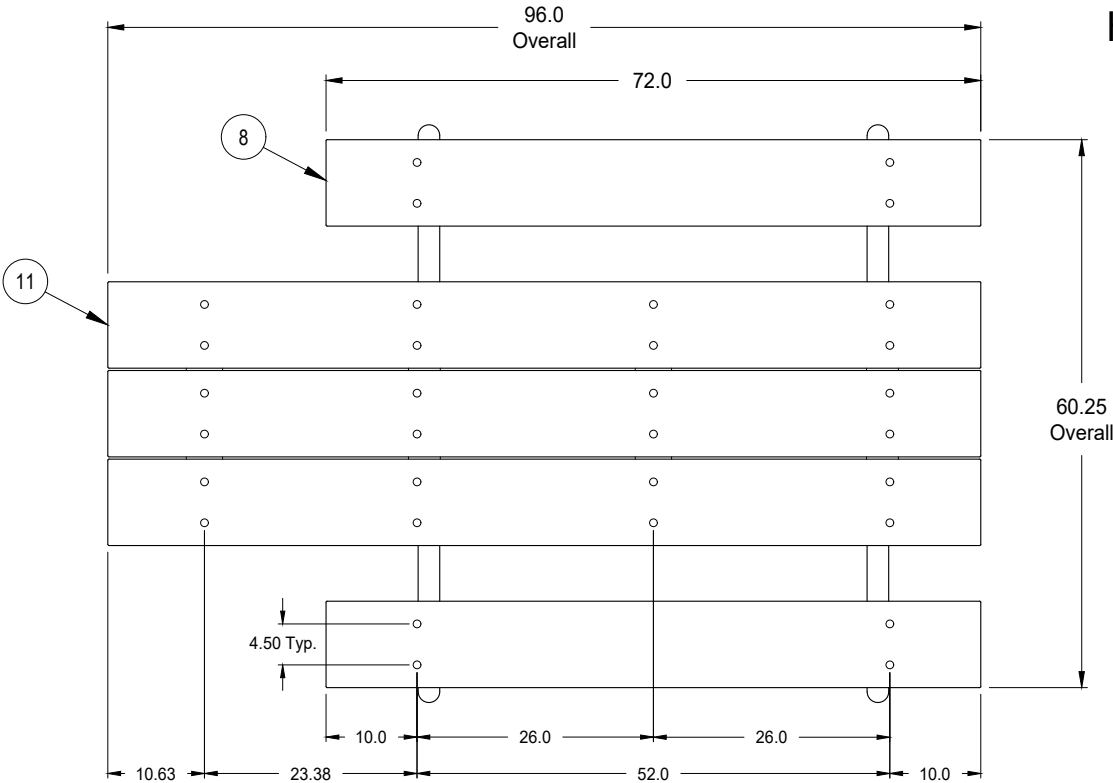

Materials:

- 2.375" O.D. x .125" Wall Steel Tube (Frame/Leg Section)
- 1" x 1" x .125" Wall Steel Tube (Diagonal Braces)
- 3/16" Thick Steel Plate (Brackets/Support)
- 3/8-16 Stainless Steel Hardware
- 2" x 10" Nominal Size P.T. Wood (Seat and Top Planks)

Finish:

- 1) Hot Dip Galvanized Frames
- 2) Painted Frames (Polyester Powder Paint over Zinc Rich Primer.)

Notes:

Dimensions shown are in inches.
Knill Fabrication Ltd. maintains a policy of continuous product improvement. As a result, some details may change without notice.

ITEM	DESCRIPTION	PART NUMBER	QTY
11	2x10x96 (Nom.) Pressure Treated Planks, Drilled for Frame	-	3
10	-	-	-
9	-	-	-
8	2x10x72 (Nom.) Pressure Treated Planks, Drilled for Frame	-	2
7	3/8-16 x 2.25" Carriage Bolt, Galvanized	-	32
6	3/8 Flat Washer, Stainless Steel	-	40
5	3/8-16 Hex Nut, Stainless Steel	-	32
4	3/8-16 x 1.25" Hex Bolt, Stainless Steel	-	4
3	Diagonal Brace, High Clearance Vs.	-	3
2	Centre Brace Plate, 2 x 10 Hole Pattern	-	2
1	Frame/Leg Section, Welded, 2 x 10 Hole Pattern	-	2

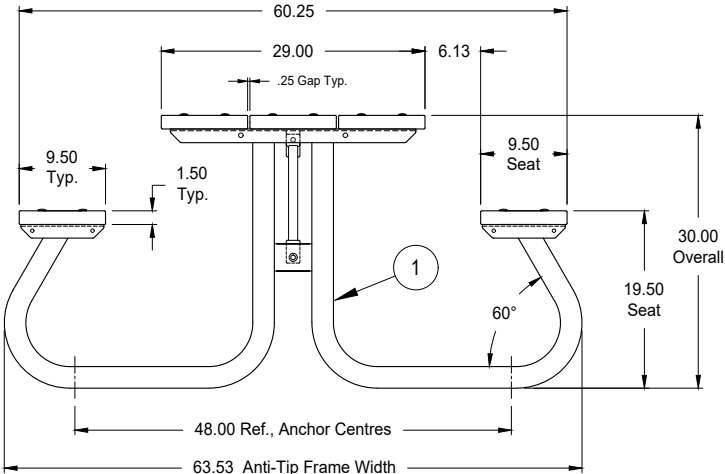
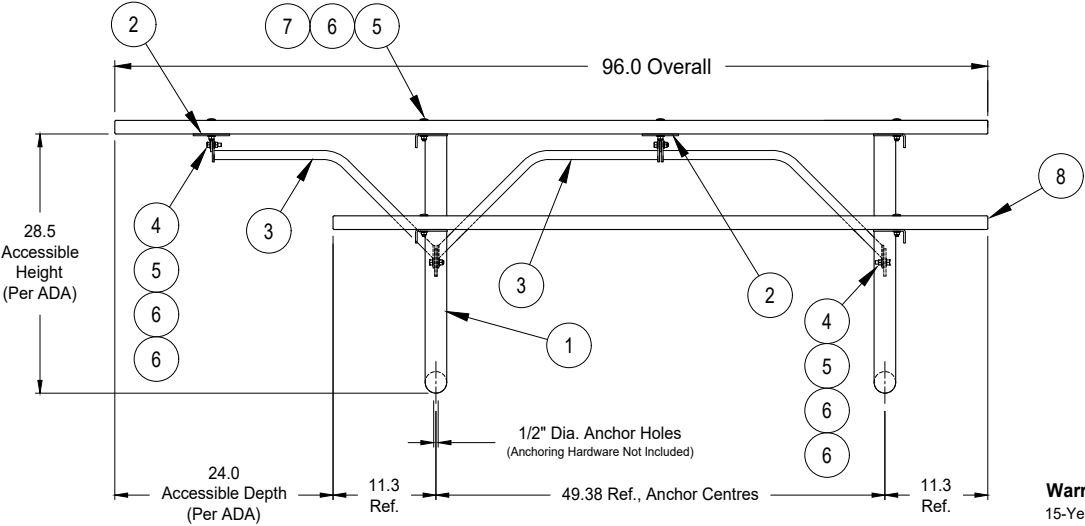

Warranty:

15-Year Limited Warranty on recycled plastic against rotting, splitting, cracking or splintering.
5-Year Limited Warranty against structural failure of all steel frames or cast aluminum components.
1-Year Limited Warranty on workmanship and/or manufacturing defects.
The above mentioned warranties do not include any cosmetic issues (e.g., scratches, dents, marring, fading of colours and discolouration of wood due to weathering.) or damage resulting from vandalism, misuse, incorrect installation/assembly or lack of maintenance and are valid only if the products are installed/assembled in conformity with the installation/assembly instructions furnished by Knill Fabrication Ltd.