

PLAN

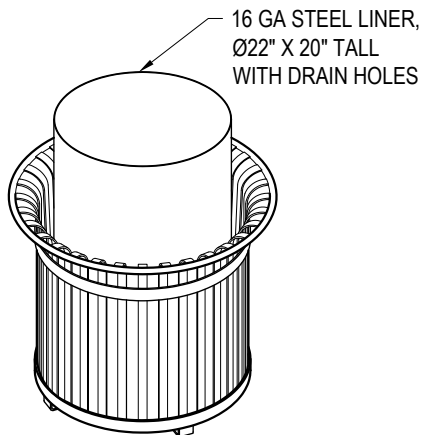

ISOMETRIC VIEW

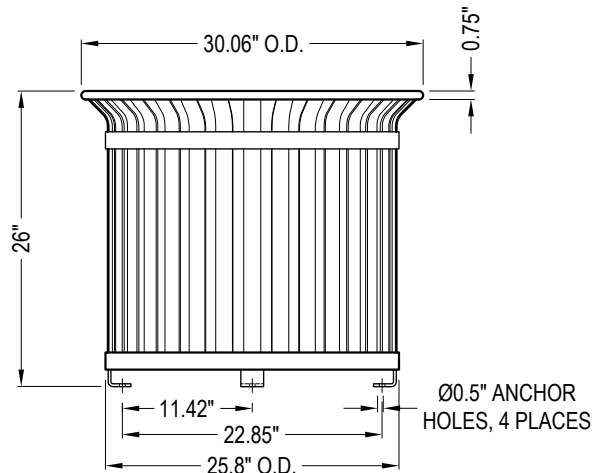

ELEVATION

**SPECIFICATIONS**

**FINISH:** POLYESTER POWDER PAINT OVER ZINC RICH PRIMER

**MATERIAL: (PICKETS)** 3/16" X 1.5" STEEL BAR, **(RINGS)** 3/16" X 1.5" STEEL BAR, **(TOP HOOP)** Ø3/4" STEEL ROD, **(SLATS AND FEET)**

1/4" X 2" STEEL BAR BASE

- ANCHORING HARDWARE NOT INCLUDED

**NOTES:**

1. INSTALLATION TO BE COMPLETED IN ACCORDANCE WITH MANUFACTURER'S SPECIFICATIONS.
2. DO NOT SCALE DRAWING.
3. THIS DRAWING IS INTENDED FOR USE BY ARCHITECTS, ENGINEERS, CONTRACTORS, CONSULTANTS AND DESIGN PROFESSIONALS FOR PLANNING PURPOSES ONLY. THIS DRAWING MAY NOT BE USED FOR CONSTRUCTION.
4. ALL INFORMATION CONTAINED HEREIN WAS CURRENT AT THE TIME OF DEVELOPMENT BUT MUST BE REVIEWED AND APPROVED BY THE PRODUCT MANUFACTURER TO BE CONSIDERED ACCURATE.
5. CONTRACTOR'S NOTE: FOR PRODUCT AND COMPANY INFORMATION VISIT [www.CADdetails.com/info](http://www.CADdetails.com/info) AND ENTER REFERENCE NUMBER 5436-070.

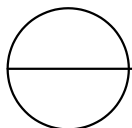

**MISCELLANEOUS SITE AMENITIES**

(224-26T) PLANTER, ROUND, FLARED TOP, 26" TALL, WITH STEEL LINER