

Vertical Slat Style 6' Bench with Back and Offset Mid Armrest - Specifications -

Rev.: 24Oct24

Model: 222-6A27

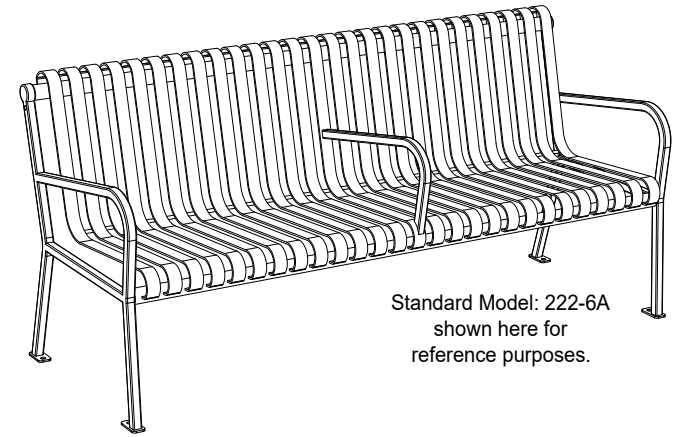

Standard Model: 222-6A
shown here for
reference purposes.

Seat Section Profile Detail

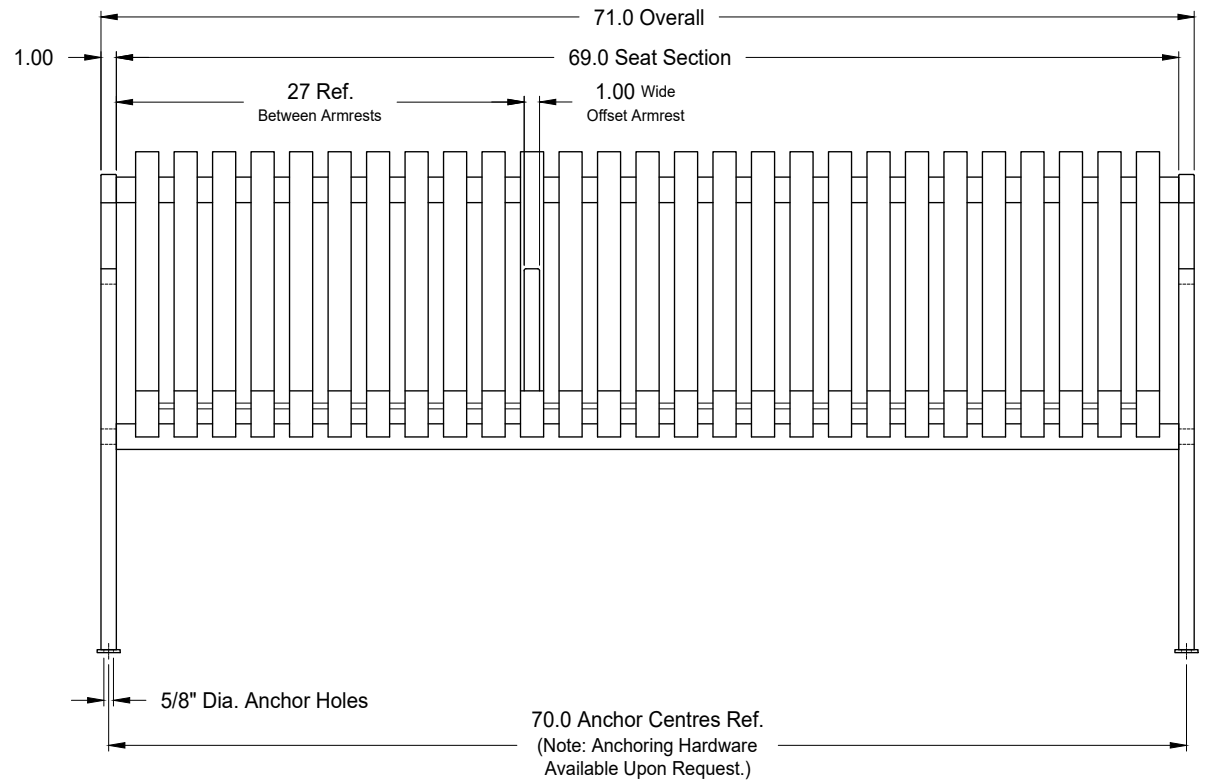
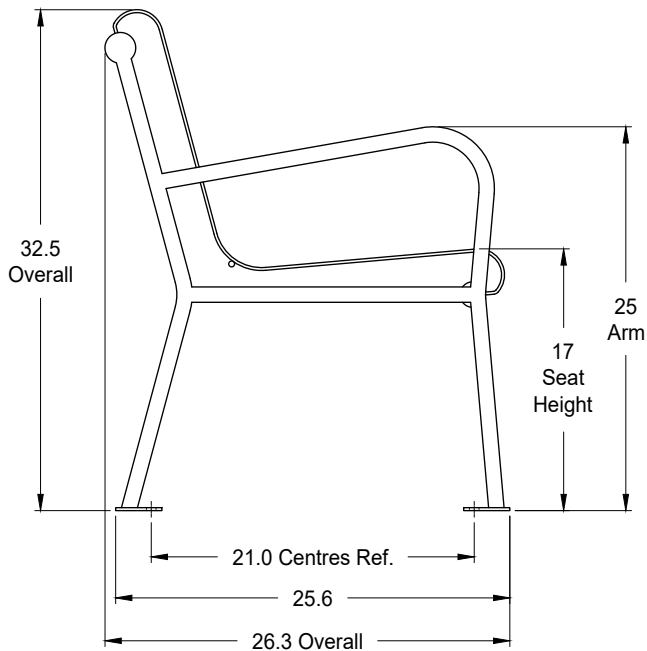
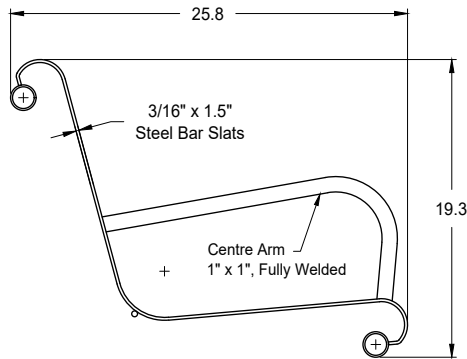

Materials:

- 3/16" x 1.5" Steel Bar Slats
- 3/8" Dia. Steel Rod
- 1.66" O.D. x .125" Wall Horizontal Tubes
- 1" x 1" x .125" Wall Square Steel Tube Leg Frames & Centre Arm
- 3/16" Thick Steel Foot Plates
- Anchoring Hardware Available Upon Request.

Finish:

Polyester Powder Paint over Zinc Rich Primer.

Notes:

- Dimensions shown are in inches.
- Matching 32 Gal. Litter Receptacle also available, Model: 223-32

Knill Fabrication Ltd. maintains a policy of continuous product improvement. As a result, some details may change without notice.

knill
Fabrication Ltd.
519-442-2424